

# EasyLog EL-2

WINDOWS™ Compatible Hand Held Data Logger

EL-2 measures, displays, records and controls temperature, humidity, pH, voltage, current, etc., with a memory for 8064 readings and a battery life of up to 3 years\*\*. EL-2 can operate as a 'stand alone' logger or be permanently connected to a system. The EL-2 serial link is addressable and up to 8 loggers can be connected to one serial port. The PC. software operates under Windows and does not require specialist skill to operate. Data output is in text format and can be easily integrated into any popular spreadsheet. Graphical output is possible under EL-WIN. Consult the EasyLog software manual for further details.

- 🌀 Battery Powered
- 🌀 Multi-function
- 🌀 Non-volatile Data Storage
- 🌀 Hand Held or Surface Mounting
- 🌀 Easy to Use
- 🌀 Cold Junction Compensation For Thermocouple Temperature Sensing
- 🌀 CE



## CONTROL SOFTWARE

### Stock Number - EL-WIN

Easy to install and use, the control software will enable the user to control one or more EasyLogs and operate them as a complete system. Supplied on a 3½" disk with a manual and serial link. EL-WIN will run under Windows 98, 95 or 3.1.

### Accessories - Cables

#### Stock Number - EasyLink

Extension connector to 'daisy chain' more than one EasyLog. One extension will be needed for each extra logger.

\* Sensor dependent.

\*\* Battery life dependent on input mode and sample rate.

Hand Held Data Logger	Stock Number EL-2		
Specification	Range	Resolution	Accuracy
Temperature ('K' type thermocouple)	-25 to +200°C	1°C	±1°C
	-13 to +392°F	1°F	±2°F
Temperature (internal)	-10 to +50°C	1°C	±1°C
	+14 to +122°F	1°F	±2°F
Humidity	5 to 95% RH	1%RH	*
pH	0 to 14pH	0.1pH*	±0.1pH*
Voltage	0 to 2V D.C.	0.01V	±1%
	0 to 20V D.C.	0.1V	
Current	0 to 2A	0.01A	±1%
Rate count	0 to 255	1 unit	N/A
Frequency	40 to 400Hz	N/A	±2Hz
Battery	3.6V ½AA lithium (up to 3 years life)**		
Serial link	8 Pin Mini DIN		
Sensor connection	Phono		
Memory capacity	up to 8064 readings		
Logging rate	1 sample per 5 seconds to 1 per 12 hours.		

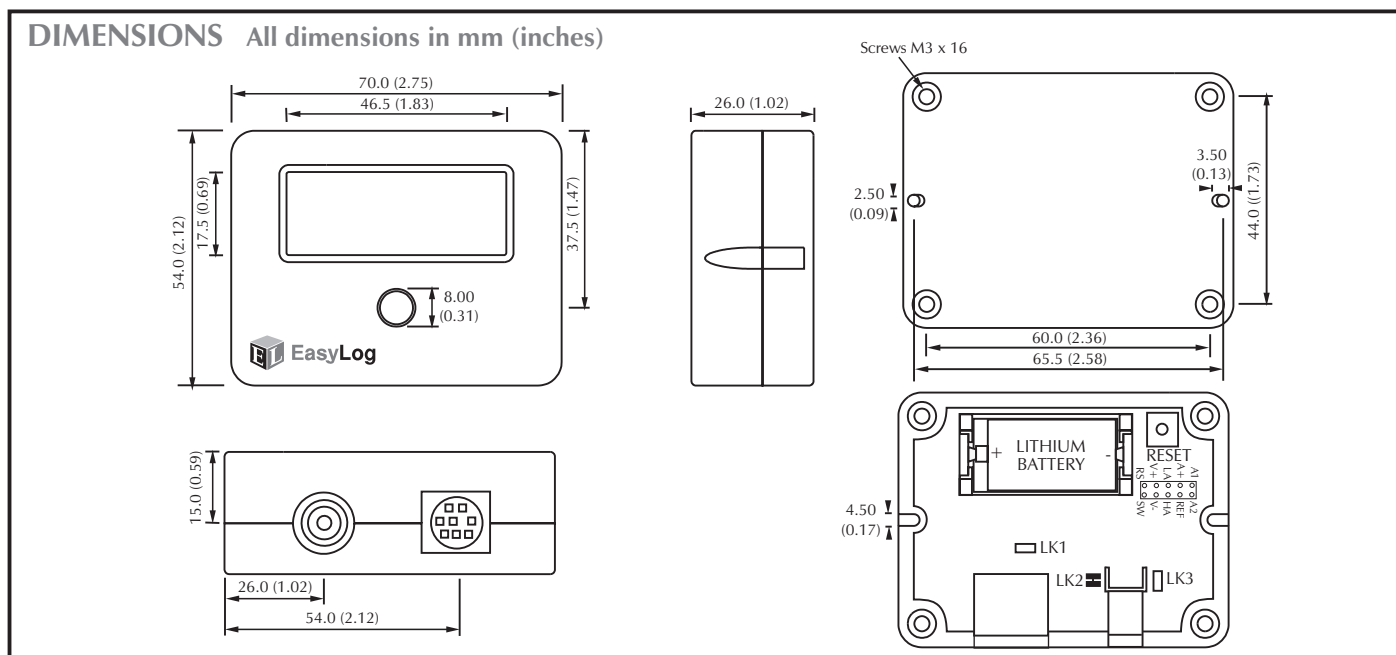

### Authorized Distributor:



Optimum Energy Products Ltd.

1-877-766-5412

[www.DataLoggerStore.com](http://www.DataLoggerStore.com)

## USING EXTERNAL SIGNALS

### PIN FUNCTION

A1, A2, REF	Output for test diagnostics. Do not use.
HA	High Alarm output = V+ when alarmed.
SW	'Push to record event' input. Active low - operated by front switch, subject to Push-to-Start.
RS	Reset input. Active low - operated by RESET switch. NOTE - logging will stop and restart at 0 time.
LA	Low Alarm output = V+ when alarmed.
A+	Output = V+ when a reading is in progress.
V+	Battery positive.
V-	Battery negative.

**DO NOT APPLY AN EXTERNAL SUPPLY VOLTAGE ACROSS THESE PINS WITH BATTERY IN PLACE.**

Only connect outputs to high impedance inputs, otherwise performance will be affected and battery life drastically reduced.

## BATTERY REPLACEMENT

Only use 1/2AA 3.6V lithium. The list below is not exhaustive. Check with supplier that the battery you are ordering is 'press fit' and is not fitted with solder tags or leads. When replacing the battery, remove the serial communications cable and ensure correct orientation of the battery.

MANUFACTURER	PART NUMBER	MANUFACTURER'S ORDER CODE
MAXELL	ER35TC	n/a
SAFT	LS3	n/a
SONNENSCHHEIN	SL-750/S	1107 501 100
TADIRAN	1/2AA/S	1551-02-210-000

**WARNING:** Handle lithium batteries carefully - observe warnings on battery casing. Dispose of in accordance with local regulations.

## VARIOUS OPERATING MODES

### Pluggable Links (Links 1 & 3)

**SHORTED**

**OPEN**

### On-Board Link (Link 2)

Normally SHORT  
Cut to OPEN

Normally OPEN  
Solder to SHORT

"K" type thermocouple

Note: For thermocouple colour coding, refer to FAQ on our website.

**TEMPERATURE (with thermocouple)**  
 A 'K' type thermocouple can be connected directly to the EL-2. The range should be selected in the EL-WIN software. Ensure Link 3 is OPEN.

**TEMPERATURE (internal)**  
 No plug needed. The EL-2 uses its internal temperature sensor. Ensure Link 3 is SHORTED. Alternatively use a phono plug which has been short circuited.

0-20V D.C.

**VOLTAGE\***  
 D.C. voltage within the ranges of 0-2V or 0-20V can be connected directly to the EL-2. Ensure that the appropriate range has been selected in advance within the EL-WIN software. For higher voltage measurement an external potential divider network should be added.

NOTES  
 1. Check link 3 is open, Link 2 is shorted.

0-2A D.C.

**CURRENT\***  
 D.C. current can be measured up to 2A maximum by using an external 1Ω 6watt shunt across the input. Select the voltage '0-2V range' in EL-WIN software and 'A' in the display symbols.

NOTE  
 1. Check Link 3 is open.

0 - 5V

**FREQUENCY\***  
 The frequency can be measured in the range 40 to 400Hz.

NOTE  
 1. Check Link 3 is open, Link 2 is shorted.

**HUMIDITY**

**pH (with internal reference)**  
 See FAQ on our website for more detailed information.

0 - 5V

**RATE COUNT\***  
 EL-2 counts the number of pulses on the input during the sample interval (e.g.: every 5s, 10s, 20s etc.). At the end of each sample interval, the count number is stored and the counter is reset to zero. A pulsed input of 0-5V can be directly connected to the EL-2. The counter is incremented on the falling edge.

NOTE  
 1. Check Link 3 is open, Link 2 is shorted.

**\*NOTES**

- When using the serial link, ensure that all signals are isolated from the computer ground.
- When using several loggers together, ensure that all signals are isolated or use the same ground.