

## Motor and drive tests keep lift station running during upgrade

### Application Note



### Testing Functions Case Study

A sewage lift pump that pumps millions of gallons per day simply can't go down. The environmental impact of that much untreated sewage spilling into a neighborhood creek would be staggering. This case tells how one pair of electricians went about testing some new electrical systems for those pumps, and how the new Fluke 1587 Insulation Multimeter met their testing needs and exceeded their expectations.

The sewage lift station in this case is part of a subsystem that supports more than 300,000 people spread over 200 square miles. The station's three pumps with combined 275 horsepower can move up to 9.2M gallons per day. In the event of a total shutdown, county workers have roughly 40 minutes to bring it back online before sewage spills into the nearby creek.

Because of this, the county pays close attention to the condition of its pump stations. As new technology has become available, has added redundancy and robustness. The pump station in this case has been upgraded several times in the 40 years since it was built. Programmable controllers were added and the relay logic was given a backup role. Redundancy was added to the power system. A medium voltage transfer switch with dual utility feeds was added along with a backup generator with its own transfer switch in case both feeds went down.

But much of the power and control systems are original, including the switchgear, motor control centers, and cabling. Three 1980-vintage motor drives were added to drive the pump motors. They have performed well, but are not worth maintaining.

**Measuring tools:** Fluke 1587 Insulation Multimeter

**Operator:** Valley Electric

**Tests conducted:** Continuity, insulation, voltage, current, frequency

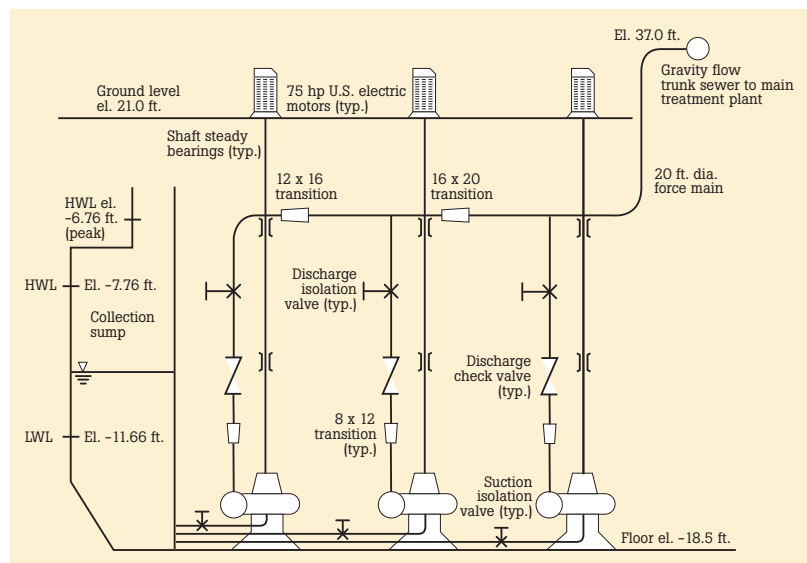

The pump station under test included wet wells, pumps, motors, and drives.

Now, the county plans to upgrade this station and four others in the next two years.

### Temporary duplication

Valley Electric Company of Everett, WA was awarded the contract to retrofit the electrical systems in the lift station. The station runs 24 hours a day, seven days a week, so bringing it down was not an option. So, Valley built a duplicate electrical system in a modular structure next to the pump house. The temporary system includes switchgear, MCC's, variable frequency drives, transfer switch, surge suppression, and harmonics and PF correction. The modular structure also houses a duplicate control system that will take input from existing sensors and control the pumps. After this temporary system is used for this pump station, the plan is to lift it by crane and move it onto the next retrofit.

To make sure that the cutover to the temporary electrical system goes smoothly, the county insisted on extensive testing of the temporary system. To complicate matters, the four 150 hp drives that were being re-used from a previous installation had been stored in a damp location and where they had probably gotten wet. The only way to be sure the drives would work at zero hour was to load test them.

### The team

Steve Uhrich and Brian Glazier with Valley Electric have commissioned dozens of new installations of all flavors. The process generally involves checking continuity, using a megohmmeter to verify insulation integrity, and infrared thermography to check for hotspots when the system is first powered. In this case, the requirement to check the drives

added a new challenge to the standard procedures. If the process was not critical, they could have used the actual pump motors to load-test the drives. But they were not allowed to take any of the 100 hp motors off line. Should they try to track down a 100 hp motor, or could they use a load bank to simulate the load?

They had access to a 500 kW load bank so they decided to investigate the feasibility of using it to test the drives. They contacted the manufacturers of both the drive and the load bank. Both manufacturers assured them that the plan to use the resistive load bank on the PWM drives was workable. "The drives wouldn't output more than 30 % of the rated load of the load bank, and we were careful to ramp up the drive quickly to get the load bank fan moving", noted Uhrich.

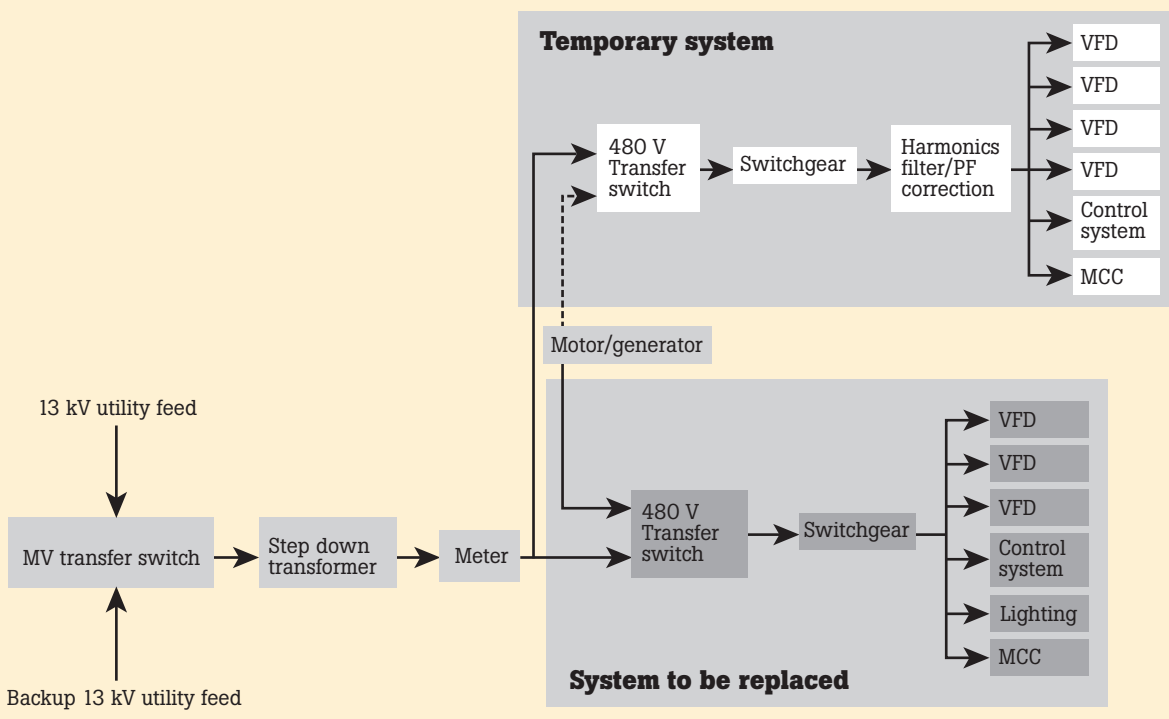

Key elements of the duplicate electrical system.

Glazier developed a detailed testing plan that incorporated key elements of conventional electrical commissioning along with the load testing. They would first check all the connections, then power up each of the four drives and run it for 15 minutes at 30 %, 60 % and 100 % of rated output. At each step they would verify that the drive was indeed putting out what was on its display. To execute the plan they planned on having a digital multimeter, megohmmeter, power quality analyzer, and IR camera.

Uhrich had recently acquired a Fluke 1587 Insulation Multi-meter and was eager to run it through its paces. The 1587 combines the functions of a digital multimeter and megohmmeter. It also includes a low pass filter that allows you to verify the output of a PWM motor drive. Because of the need to check continuity, voltage levels, insulation integrity and drive performance, this case was a golden opportunity to use many of the 1587 functions.

### Testing the system

Prior to connecting the new system to utility power, Uhrich and Glazier tested the incoming cabling and switchgear. The 1000 volt insulation testing and continuity functions of the 1587 were used during this initial testing. They insulation-tested each of the conductors to ground and to each other. During this phase of testing they found that one of the phase conductors from the fused disconnect, feeding the temporary switchgear, had only 400 k ohms resistance to ground. It should have been at least in the megohms. They replaced the cable before proceeding.

Once they powered the system, they took measurements at the utility meter to make sure they were not pulling excessive current and that voltage was close to 277 V. The 600 V CAT IV 1587 was well suited for voltage measurements at every point in this system, from the temporary feed at the utility CT can, all the way to the drives. And with a current clamp accessory (the Fluke i400s with adapter), it could measure the current, too.

Each of the drives was connected to the load bank and powered up in turn. At each of the three output levels, Uhrich and Glazier took current readings to make sure the current to the load bank was within tolerance. They took voltage and frequency measurements and correlated them to the drive display. The low pass filter on the 1587 makes it possible to take voltage and frequency readings that correspond to the PWM envelope rather than the individual pulse that make up the waveform. The low pass readings can be directly compared to the drive display.

After each drive was running for 45 minutes, Glazier took infrared thermographs of the drive and switchgear to make sure there were no hot spots.

Uhrich said, "I carry a lot of test instruments in my truck, but with the versatility of the 1587, I can grab one meter and perform all the tests needed for troubleshooting, maintenance or commissioning."

The new switchgear and the Fluke 1587 performed well. The county and the team at Valley Electric were all pleased with the outcome of the innovative drive testing. After this thorough testing everyone has higher confidence that the temporary electrical equipment is going to support the station during the renovation.



Steve Uhrich tests resistance of drive cabling.

**Fluke.** *Keeping your world up and running.*

**Fluke Corporation**  
PO Box 9090, Everett, WA USA 98206

**Fluke Europe B.V.**  
PO Box 1186, 5602 BD  
Eindhoven, The Netherlands

**For more information call:**  
In the U.S.A. (800) 443-5853 or  
Fax (425) 446-5116  
In Europe/M-East/Africa (31 40) 2 675 200 or  
Fax (31 40) 2 675 222  
In Canada (800)-36-FLUKE or  
Fax (905) 890-6866  
From other countries +1 (425) 446-5500 or  
Fax +1 (425) 446-5116  
Web access: <http://www.fluke.com/>

©2005 Fluke Corporation. All rights reserved.  
Printed in U.S.A. 4/2005 2444771 A-US-N Rev A